

00117822

Variofix block S



- ▶ For virtually gap-free surface element mounting
- ▶ For subsequent installation in closed frame constructions
- ▶ The asymmetrical design and cover cap enable the surface elements to be mounted in different positions: flush with the profile edge or in front of the profile
- ▶ Retainer ring for connecting the screw to the surface element (Machinery Directive 2006/42/EC)

Required accessories:

Screw for fastening the surface element

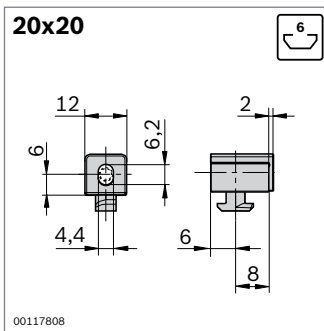

00117808

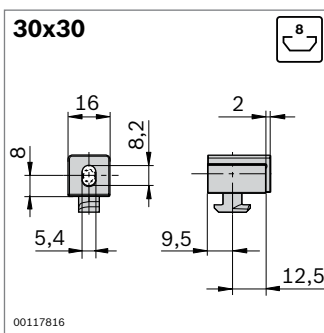

00117816

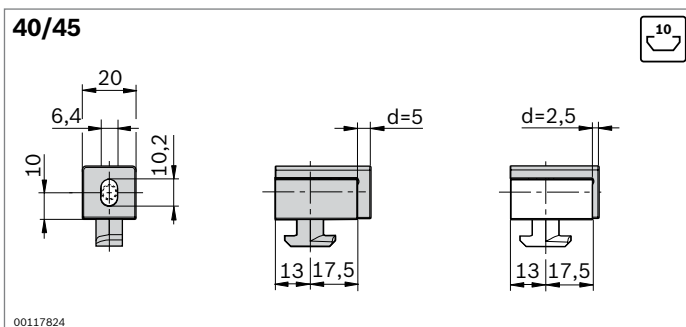

00117824

Variofix block S	Color	Slot	No.	No.
20x20	Signal gray	6	10	3 842 548 836

Material: PP
Square nut: steel; galvanized
Scope of delivery: incl. square nut M4, cap

Variofix block S	Color	Slot	No.	No.
30x30	Signal gray	8	10	3 842 548 838

Material: PP
Square nut: steel; galvanized
Scope of delivery: incl. square nut M5, cap, retainer ring

Variofix block S	Color	Slot	No.	No.
40/45	Signal gray	10	10	3 842 548 840

Material: PP
Square nut: steel; galvanized
Scope of delivery: incl. square nut M5, 2 x cap (d = 2.5 mm; d = 5 mm), retainer ring